

Universal & 800 Series High Performance Tap

 HSSE PM HSSE TN TA					
	Material groups	P M K N S	P M K N S	P M K N S	P M K N S
	Hole type				
	Coating	TA	TA	TN	TN
Chamfer	B / 4-5P	C / 2-3P	B / 4-5P	C / 2-3P	
Tolerance	2BX	2BX	2B	2B	

UNC	UNC	P	L1	L2	L3	Ød2	a		MTSP	MTSF	800SP-BT	800SF-CT
	DIN 371								EDP	EDP	EDP	EDP
4-40	40	56	5	18	3.5	2.7	2.35		FT1276	FT1289		
5-40	40	56	7	18	3.5	2.7	2.65		FT1277	FT1290		
6-32	32	56	6	20	4.0	3.0	2.85		FT1279	FT1292		
8-32	32	63	7	21	4.5	3.4	3.50		FT1280	FT1293		
10-24	24	70	8	25	6.0	4.9	3.90		FT1274	FT1287		
1/4-20	20	80	13	30	7.0	5.5	5.10		FT1273	FT1286		
5/16-18	18	90	13	35	8.0	6.0	6.60		FT1278	FT1291		
3/8-16	16	100	15	39	10.0	8.0	8.00		FT1275	FT1288		
	DIN 376											
7/16-14	14	100	15		9	7	9.40		FT1284	FT1297		
1/2-13	13	110	18		4.5	3.4	10.80		FT1281	FT1295		
9/16-12	12	110	20		6	4.9	12.20		FT1285	FT1298		
5/8-11	11	110	22		6	4.9	13.50		FT1283	FT1296		
3/4-10	10	125	32		14.0	11.0	16.50				FT1282	FT1294









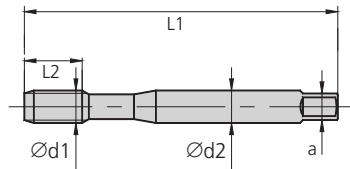

Material groups	ISO	Vc-m/min Cutting Speed			
Steels	P	5-40	5-40	5-35	5-40
Stainless Steels	M	5-15	5-15	5-15	5-15
Cast Irons	K	10-30	10-30	10-25	10-25
Non-Ferrous Metals	N	10-30	10-30	10-30	10-30
Special Alloys	S	1-8	1-8		

Example of order

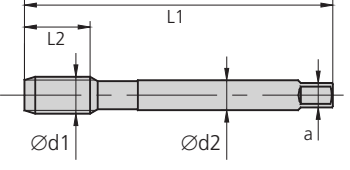
MTSP - 4-40
or
EDP - FT1276

Universal & 800 Series

High Performance Tap

 HSSE PM HSSE TN TA						
						
	Material groups	P M K N S	P M K N S	P M K N S	P M K N S	P M K N S
	Hole type					
	Coating	TA	TA	TN	TN	TN
Chamfer	B / 4-5P	C / 2-3P	B / 4-5P	C / 2-3P	C / 2-3P	
Tolerance	2BX	2BX	2B	2B	2B	

UNF

UNF	P	L1	L2	L3	Ød2	a		MTSP	MTSF	800SP-BT	800SF-CT
DIN 371								EDP	EDP	EDP	EDP
4-48	40	56	12	20	4.0	2.7	2.40	FT1301	FT1313		
6-40	36	63	12	21	4.5	3.0	2.95	FT1302	FT1322		
10-32	32	70	14	25	6.0	4.9	4.10	FT1300	FT1312		
1/4-28	28	80	18	30	6.0	5.5	5.50	FT1299	FT1311		
5/16-24	28	90	20	35	8.0	6.0	6.90	FT1306	FT1317		
3/8-24	24	100	20	39	10.0	8.0	8.50	FT1305	FT1316		
DIN 376											
7/16-20	20	100	15		8.0	6.2	9.90	FT1308	FT1319		
1/2-20	20	100	15		9.0	7.0	11.50	FT1303	FT1314		
9/16-18	18	100	15		11.0	9.0	12.90	FT1310	FT1321		
5/8-18	18	100	15		12.0	9.0	14.50	FT1307	FT1318		
3/4-16	16	110	24		14.0	11.0	17.50			FT1304	FT1315
7/8-14	14	124	24		18.0	14.5	20.40			FT1309	FT1320

Material groups	ISO	Vc-m/min Cutting Speed			
Steels	P	5-40	5-40	5-35	5-40
Stainless Steels	M	5-15	5-15	5-15	5-15
Cast Irons	K	10-30	10-30	10-25	10-25
Non-Ferrous Metals	N	10-30	10-30	10-30	10-30
Special Alloys	S	1-8	1-8		

Example of order

800SP-BT - 3/4-16
 or
 EDP - FT1309



Where *high performance*
is the *standard*[®]

Дистрибьютор:

ООО "ВЕЛЛКАМ"

127247 Москва,
Дмитровское ш. 100 стр.2

Тел. +7 (499) 685 00 69
email: info@wellcam-ps.ru
www.wellcam-ps.ru

M.A. Ford Europe Ltd.

Unit 38, Royal Scot Road
Pride Park, Derby
DE24 8AJ United Kingdom

Phone: +44(0) 1332 267960
Fax: +44(0) 1332 267969
e-mail: sales@mafordeurope.com

mafordeurope.com

Also available:

